



JAYPRO SPORTS LLC

BASKETBALL SYSTEM

MODEL: JAYPRO TSP-200

**ASSEMBLING INSTRUCTIONS
AND OWNER'S MANUAL**

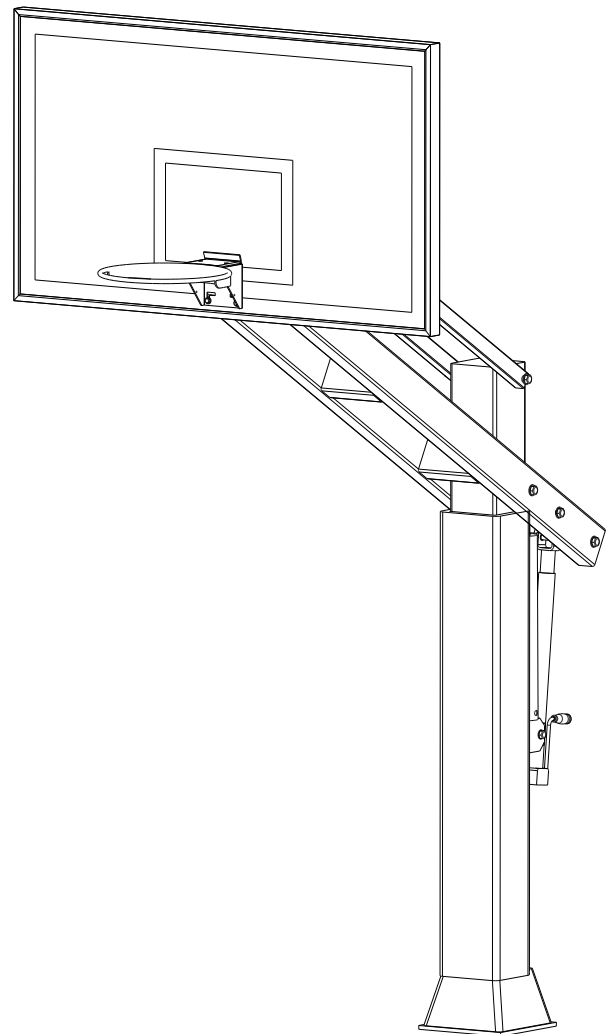

⚠ WARNING ⚠

FAILURE TO COMPLY WITH ANY OF THE WARNINGS IN THESE INSTRUCTIONS MAY RESULT IN SERIOUS PERSONAL INJURY.

FAILURE TO COMPLY MAY ALSO RESULT IN PROPERTY DAMAGE. PLEASE HEED ALL WARNINGS AND CAUTIONS TO ENSURE YOUR SAFETY.

DO NOT ATTEMPT TO ASSEMBLE THIS SYSTEM WITHOUT CAREFULLY READING AND FOLLOWING ALL INSTRUCTIONS. BEGIN BY IDENTIFYING AND TAKING INVENTORY OF ALL PARTS USING THE PARTS LIST PROVIDED.

Keep this instruction manual in case you have to contact the manufacturer for replacement parts.

**TOOLS AND MATERIALS REQUIRED FOR ASSEMBLY
(Not Included)**

- | | |
|--------------------------|---|
| 1. 2 Adjustable Wrenches | 10. Concrete-1/2 yard or 14-16
Bags, (80 lb. bags) |
| 2. Socket Set | 11. Phillips Head Screwdriver |
| 3. 9/16" Wrench | 12. Electric Drill |
| 4. 3/4" Wrench | 13. Carpenter's Level |
| 5. 15/16" Wrench | 14. A minimum of 2 Ladders |
| 6. 1/2" Wrench | 15. Water Supply |
| 7. Hammer or Mallet | 16. Degreaser |
| 8. Tape Measure | 17. 1/4" Drill Bit |
| 9. Shovel | |

**** A MINIMUM OF SIX ADULTS IS
REQUIRED TO LIFT UNIT INTO PLACE ****

STOP!

BEFORE YOU START

STOP!

- A. Identify and inventory all parts using the checklist boxes in the parts list. Be sure to keep the hardware bags and their contents separate. If any parts are missing call our Customer Service Department (800-243-0533) outside the U.S. 1-214-232-3215.
- B. Test fit all Bolts by inserting them into the respective hole. If necessary, carefully scrape away any excess powder coating buildup from inside the holes. Do not scrape away all of the powder coating. Bare metal may rust.



SAFETY INSTRUCTIONS



FAILURE TO FOLLOW THESE SAFETY INSTRUCTIONS MAY RESULT IN SERIOUS INJURY OR PROPERTY DAMAGE AND WILL VOID THE WARRANTY. The owner must ensure that all players know and follow these rules to safely operate the system. Proper and complete assembly, use and supervision is essential for proper operation and to reduce the risk of accident or injury. A high probability of serious injury exists if this system is not installed, maintained, or operated properly.

If using a ladder during assembly, use extreme caution. Follow all warnings and cautions on the ladder carefully. 6 people are required to lift the unit into place. Before digging, contact the appropriate agency to locate underground power cables, gas, and water lines. Do not install the system within 20 feet of overhead power lines. Climate, corrosion, or misuse could result in system failure. If technical assistance is required, contact the manufacturer. Minimum operational height is 7'6" to the Rim. Most injuries are caused by misuse and/or failure to follow instructions. Use caution when using the system.

Required For This Page:
15/16" Wrench

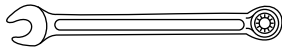

Shovel
Tape Measure

TC
(8PCS)

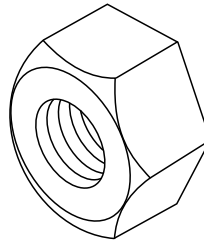

BH0001

****ONLY ONE ADULT IS REQUIRED FOR THE FOLLOWING STEPS****

STEP A

NOTE: Before digging, call to locate any buried utility lines.

- a. Dig a hole 48" deep and 21"x21" square. The edge of the hole should be flush with the edge of the playing surface. If you live in an area where heavy frost can occur, it may pose a problem, consult your local building inspector to determine the appropriate hole depth.

NOTE: The hole must be at least 48" deep.

- b. Build a form before pouring the concrete pad, to ensure that the top of the concrete remains straight and square. The form should be placed about 1/2" above the playing surface to allow for water drainage.
- c. Bell out the bottom of the hole.

NOTE: A square hole prevents the rotation of the concrete.

NOTE: The area behind the playing surface must be cleared off by at least 3 feet to enable the user to stand behind the pole to adjust the Rim height.

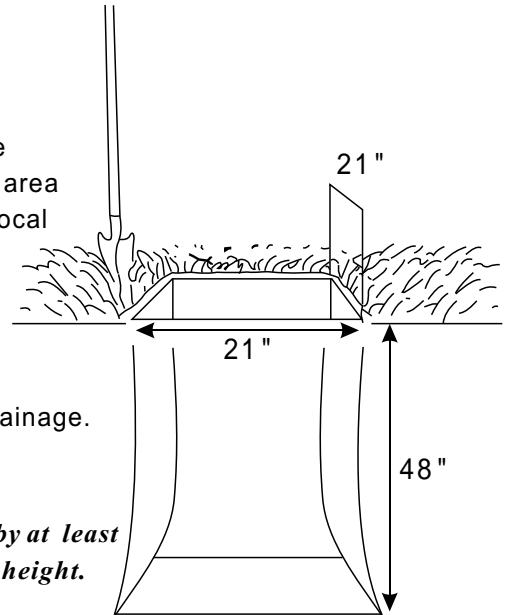

STEP B

- A. Thread a 5/8" Hex Nut (TC) onto each of the 5/8"x16" J-Bolts (AA). Securely tighten the Nuts all the way down to the end of the threads.
- B. Slide the threaded ends of the J-Bolts through the holes in the corners of the J-Bolt Template (AB) and secure them with 5/8" Hex Nuts (TC) as shown. Securely tighten all Nuts at this time.

NOTE: Make sure the curved "J" ends of the J-Bolts are oriented in a rectangular pattern, as shown.

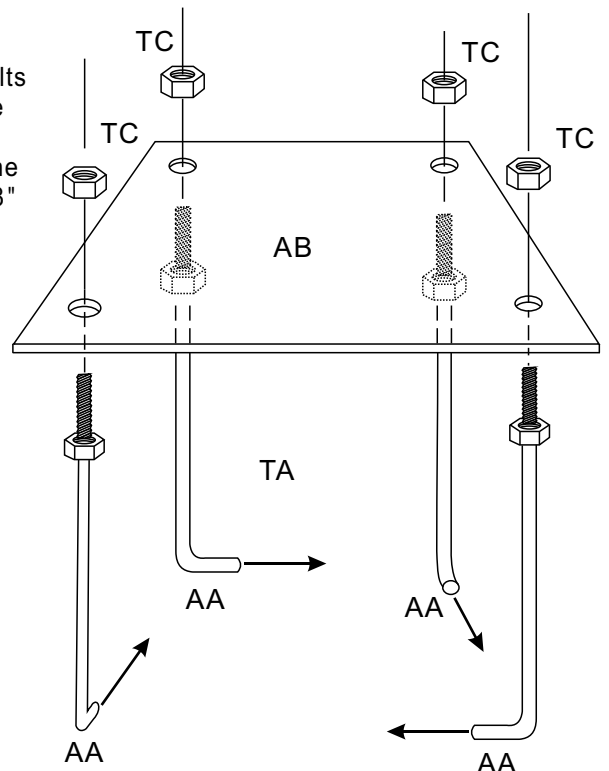
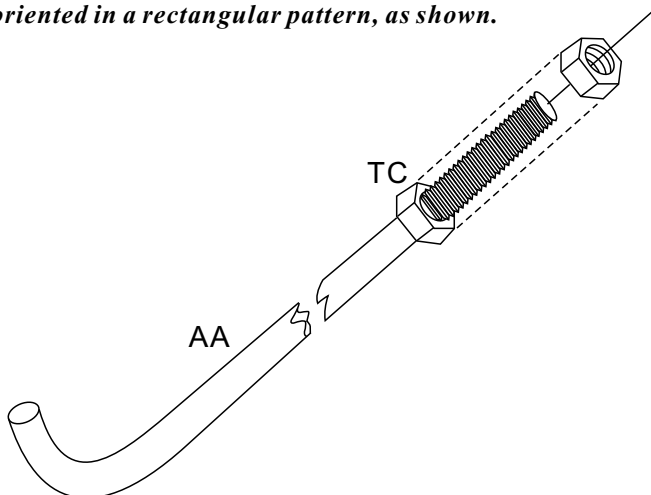

STEP C

- Mix the concrete according to the instructions on the bags. Note that a thicker mix of concrete will dry stronger than a thin mix. Pour the concrete into the hole, stopping approximately 18 inches from the top of the hole.
- Insert the four pieces of 36" Rebar (AC) into the hole, pushing each piece firmly to the bottom of the hole. The four pieces should be arranged in a square approximately 8 inches wide so that each piece of rebar will be positioned next to the J-Bolts when the J-Bolt Template is placed in the cement.
- Finish filling the hole to the top with concrete. The top of the concrete should reach just above the level of the top of the form.

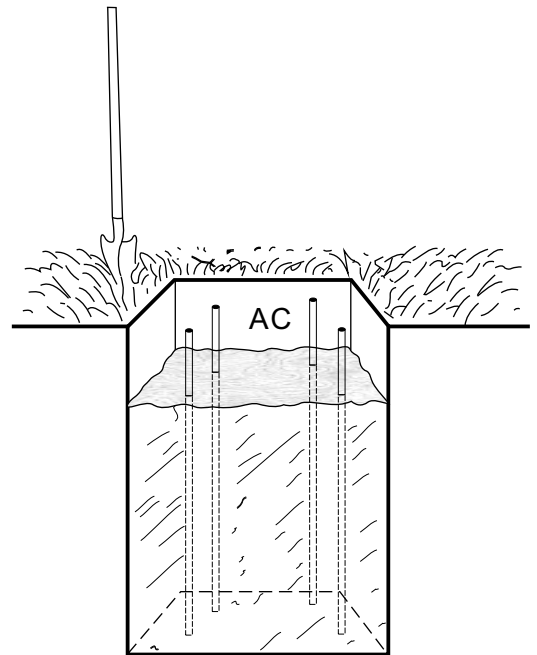

STEP D

- Position the J-Bolt Template (AB) over the hole so that it is centered, with the sides of the plate square with the sides of the hole.
- Push the J-Bolts (AA) into the concrete until the J-Bolt Template is resting flat against the surface of the concrete.
- Grasp the tops of the J-Bolts and agitate the Template assembly back and forth repeatedly to eliminate any air bubbles in the concrete. Lift the Template slightly above the concrete when agitating. Make sure the Template is resting on the concrete after agitating. Form the concrete into a downward slope away from the Pole to allow water runoff.
- Clean off any concrete that may be on the J-Bolt Template or the exposed portions of the J-Bolts.
- Using a carpenter's level, make sure the Template is square to and level with the playing surface.
- Allow the concrete to cure for a **minimum** of 72 hours before installing the rest of your basketball system. In cold, wet weather or humid climates, allow additional time for the concrete to cure.

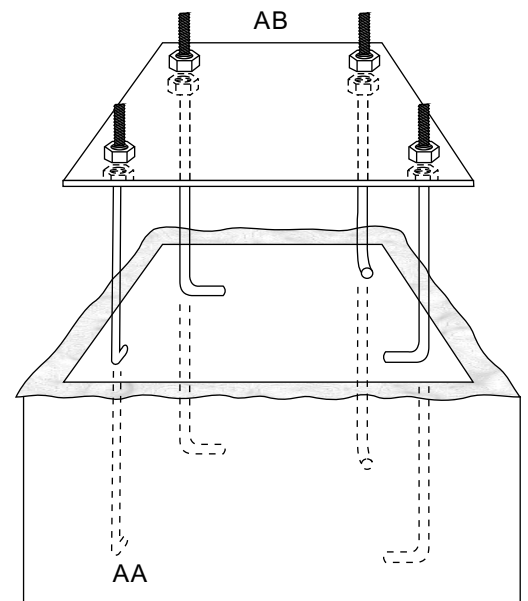

YOU ARE NOW FINISHED WITH THE INITIAL ASSEMBLY STEPS. DO NOT PROCEED WITH THE ASSEMBLY UNTIL THE CONCRETE HAS FULLY CURED. CURING WILL TAKE A MINIMUM OF 72 HOURS. IN HUMID CLIMATES OR WET WEATHER, ALLOW ADDITIONAL TIME FOR THE CONCRETE TO CURE.



WARNING



NEVER USE THE SYSTEM WITHOUT FOLLOWING THE CEMENTING INSTRUCTIONS. FAILURE TO FOLLOW ALL OF THESE INSTRUCTIONS AND WARNINGS COULD LEAD TO SERIOUS PERSONAL INJURY OR PROPERTY DAMAGE AS LISTED ON PAGE ONE.

Required For This Page:

5/8" Wrenches

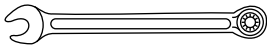

Jp0001

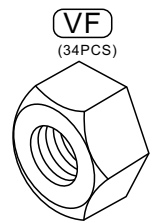
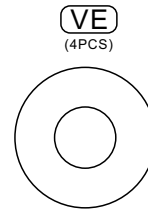
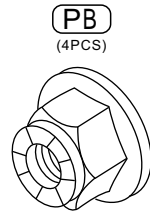
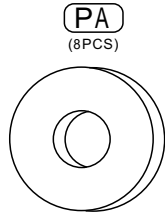

VD
(2PCS)

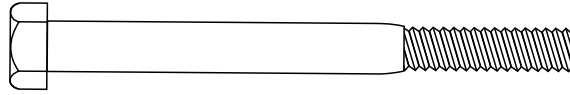

WARNING



BECAUSE OF THE SIZE AND WEIGHT OF THE SYSTEM, A MINIMUM OF THREE ADULTS ARE REQUIRED FOR THE FOLLOWING STEPS

STEP 1

- A. Slide a 5/8" Flat Washer (PA) over each of the J-Bolts (AA) in the corners of the J-Bolt Template (AB) as shown in FIGURE 1A.
- B. Slide a 5/8 Flat Washer (PB) over each of the J-Bolts(AA).
- b. Thread a 5/8 Nylock Flange Nut(PC) to each J-bolt. Tighten the Nuts only a few turns onto the J-Bolts as shown in FIGURE 1B. Do not tighten the Nuts all the way down to the Plate at this time.

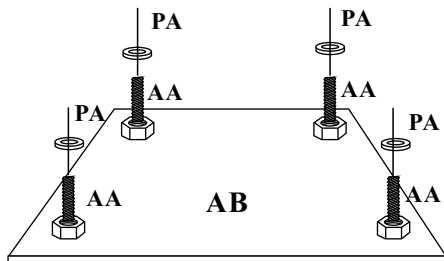

FIGURE 1A

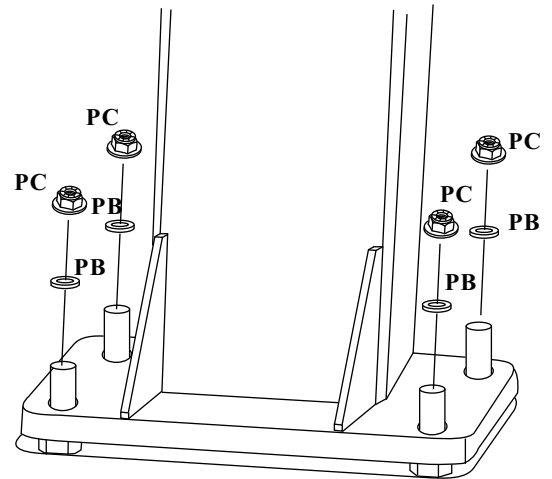
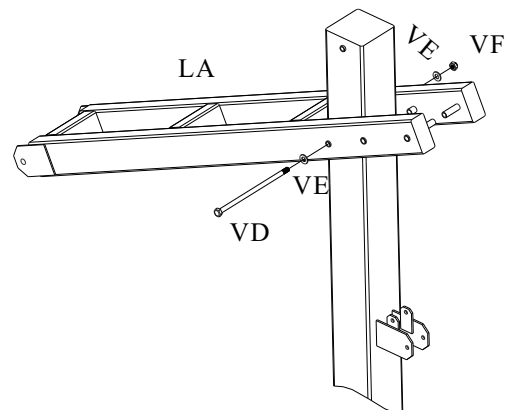

FIGURE 1B

STEP 2

- A. Slide the Low Extension Arm(LA) to the pole, apply a small amount of grease to a Hex Head Bolt(VD), slide the greasing Bolt (VD) through a Flat Washer(VE), holes on Low Extension Arm, holes on pole, other Flat Washer(VE), then secure the Hex Head Bolt(VD) with a Lock Nut(VF). But don't tighten the Nuts too much.



Required For This Page:

5/8" Wrenches



VE
(6PCS)



VF
(3PCS)



VJ
(2PCS)

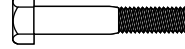

VD
(1PCS)

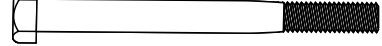

JP0002

STEP 3

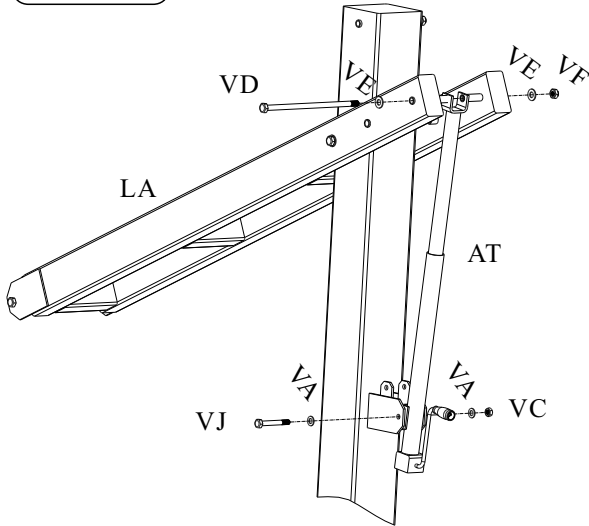

- A. Slide the actuator to the extension arm. Apply a small amount of grease to a Hex Head Bolt(VD), slide the greasing Bolt (VD) through a flat Washer(VE), the hole in Low Extension Arm(LA), the hole on Actuator(AT), another flat Washer (VE), then secure the Bolt with a lock Nut(VF) But don't tighten the Nuts too much.
- B. Slide a Hex Bolt(VJ) through a flat Washer(VA), the holes on the Actuator bracket, holes on Actuator(AT), another flat Washer(VA), then secure the Bolt with a lock Nut(VC).

STEP 4

- A. Slide the Upper Extension Arm(UA) to the pole, apply a small amount of grease to a Hex Head Bolt(VG), slide the greasing Bolt (VG) through a Flat Washer(VH), holes on Upper Extension Arm, holes on pole, other Flat Washer(VH), then secure the Hex Head Bolt with a Lock Nut(VI). But don't tighten the Nuts too much.

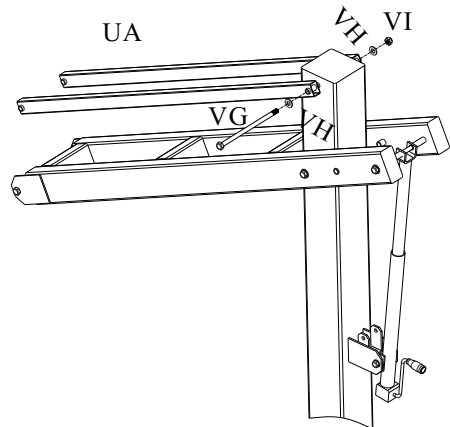

STEP 5

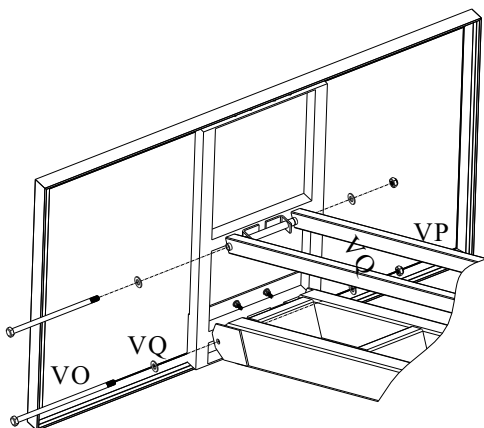

- A. Position the backboard to the low extension. Applying a small amount of grease to a Hex Head Bolt(VO), slide the greasing Bolt (VO) through a flat Washer(VQ), the holes on the upper extension arm and the backboard, another flat Washer(VQ), then secure the Bolt with a Lock Nut(VP).
- B. Slide the backboard to the upper extension arm by repeat the step above.

Required For This Page:

5/8" Wrenches



VE
(6PCS)

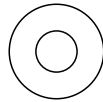

VF
(3PCS)



VD
(1PCS)

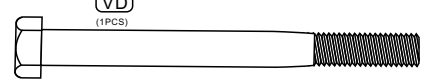

JP0002

STEP 6

- A. Position the two Spring assists(SS) to the Low Extension Arm(LA), slide a Hex Head Bolt through a Flat Washer (VE), the hole on Low Extension Arm, the holes on Spring Assit(SS), another flat Washer(VE), then secure the Bolt with a lock Nut(VF).
- B. Position the bottom of the Spring Assist to the Actuator Bracket, slide a Hex Bolt(VN) through a flat Washer(VA), the holes on the Spring Assists, the holes on Actuator Bracket(AP), another flat Washer(VA), then secure the Bolt with a lock Nut(VC).
- C. Takt off the PVC Washer on the top of the Spring Assists.

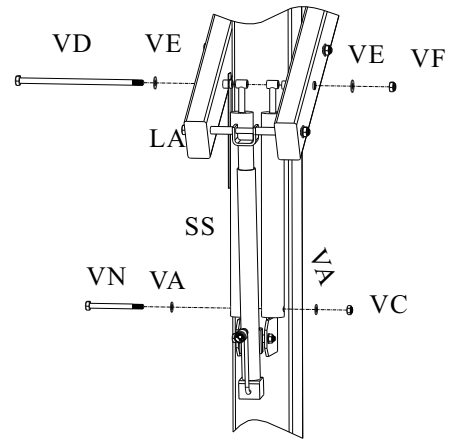

STEP7

Please follow these steps to install the stop rebar to the pole. This stop will stop the Low Extension Arm when the system is adjusted at the lowest point.

- A. Insert the Steel Rebar(A) to the steel tube on the back of pole.
- B. Insert the Pin(B) through the hole on the steel tube(C) and the hole on steel rebar(A).
- C. Lock the Pin(B) as shown.

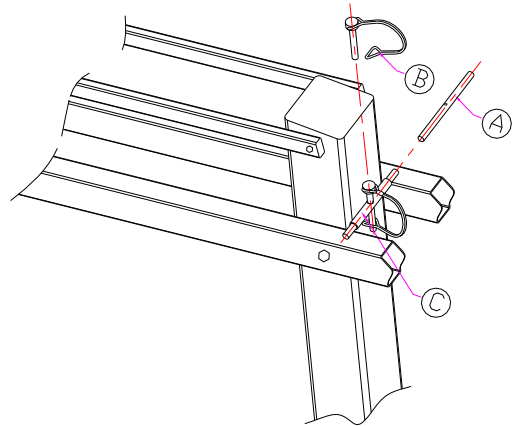

STEP 8

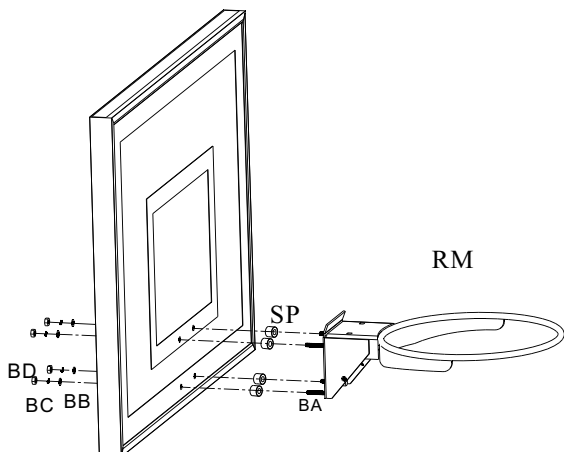

- A. Insert the 4 PVC Spacers(SP) to the 4 holes on the backboard.
- B. Slide Hex Bolts(BA), each one through the holes on the Rim and the rubber spacer, and the holes on the backboard, a Flat Washer(BB), a Lock Washer(BC), then secure the Hex Bolt with a nut(BD).

****A MINIMUM OF THREE ADULTS IS REQUIRED FOR THIS STEP****

STEP 9

WARNING: *At least two adults must hold the Pole steady while leveling the system.*

- A. Using a carpenter's level on the face and the side of the Backboard, adjust the tightness of the Nuts between the J-Bolt Template and the Pole plate until the Pole plate is resting evenly on all four Nuts, with the Backboard hanging perfectly vertical.
- B. Making sure the Pole remains perfectly vertical, securely tighten the Nuts (PC) above the Pole plate until they rest against the plate.
- C. Turn the center Hex Bolt (TB) until it rises to the plate.

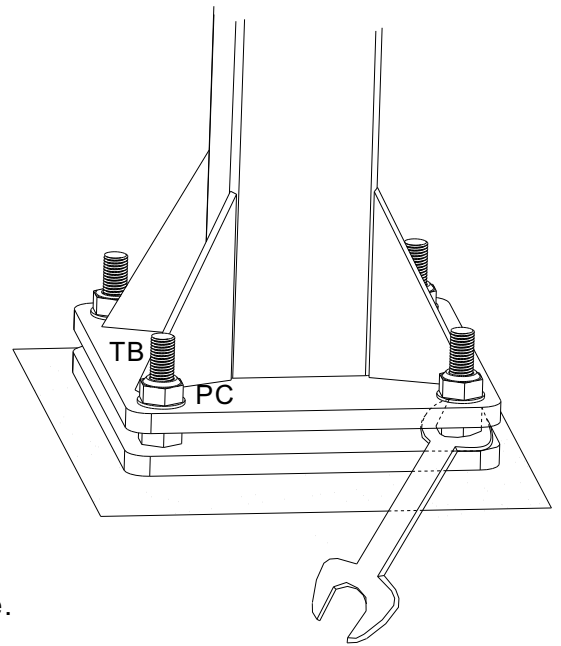

STEP 10

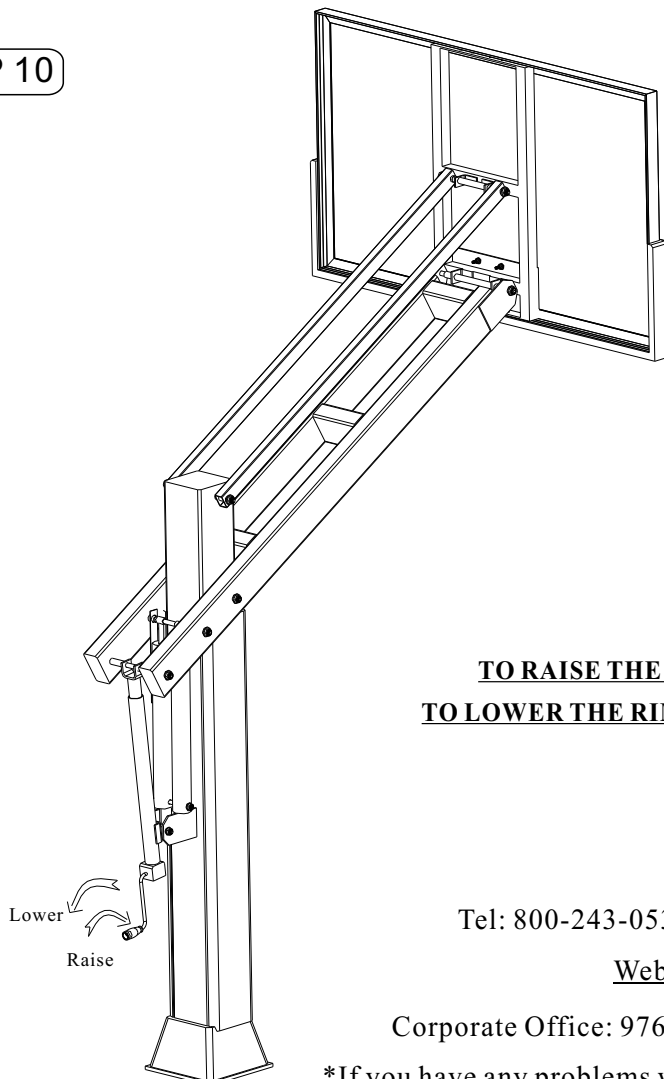

To Adjust Rim height:

TO RAISE THE RIM: Turn the crank handle clockwise

TO LOWER THE RIM: Turn the crank handle counter clockwise

Tel: 800-243-0533

Fax: (214)528-2662

Web: www.jaypro.com

Corporate Office: 976 Hartford Turnpike Waterford, CT 06385

*If you have any problems with your basketball system please contact us *