

OWNER'S MANUAL

WARNING

FAILURE TO FOLLOW THESE WARNINGS MAY RESULT IN SERIOUS INJURY AND/OR PROPERTY DAMAGE.

Owner must ensure that all players know and follow these rules for safe operation of the unit.

- Do not dunk on this unit
- Do not hang from any part of the unit, including the backboard, rim, or net.
- Do not slide, climb, or play on pole.
- Keep organic material away from pole base. Grass, litter, etc. could cause corrosion and/or deterioration.
- Check pole system twice a year for signs of corrosion (rust, pitting, chipping). Remove rust and/or loose paint completely and repaint with exterior enamel paint. If rust has penetrated through the steel anywhere, replace pole immediately.
- Check unit before each use for loose hardware, excessive wear, and signs of corrosion and repair before using.
- During play, use extreme caution to keep players face away from the backboard, rim, and net.
- Wear a mouthguard when playing to avoid dental injuries.
- When adjusting height, keep hands and fingers away from moving parts.
- During play, do not wear jewelry (rings, watches, necklaces, etc.). Objects may entangle in net.



Model III BASKETBALL SYSTEM

MODEL NUMBER
B2306

Thank you for purchasing our basketball system. We try hard to ensure that our products are of high quality and free of manufacturing defects and of missing parts. However, if you have any problems with your basketball pole, such as a manufacturing defect or a missing part, please **DO NOT RETURN IT TO THE STORE**. Call us at:

TOLL FREE 1-888-USA-GOAL
(THIS IS A CONSUMER ONLY NUMBER)
FAX: (812) 467-1399

Or write us at:

CUSTOMER SERVICE DEPT., P.O. Box 889, Evansville, IN 47706

Please provide model number, serial number, and/or part number of the product and/or part when you call or write. These numbers can be found on the product, packaging, or in this owner's manual.

ESCALADE[®] SPORTS

Please visit our World Wide Web site at:

<http://www.escaladesports.com>

To make assembly of your basketball pole easier, use the Hardware Identifier on page 2 to identify and sort all fasteners.

Do not tighten hardware until instructed to do so. If hardware is tightened too soon, mounting holes may not align and parts may not fit together. Leave locknuts slightly loose until you are instructed to tighten them.

Read this manual all the way through before starting to put up your pole. Then read each step completely before beginning that step. **Some smaller parts may be shipped inside larger tubes. Check inside tubes before assembling or ordering parts.**

HARDWARE IDENTIFIER

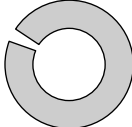
25

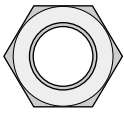
 3/8" SPLIT WASHER
 (4 PIECES)

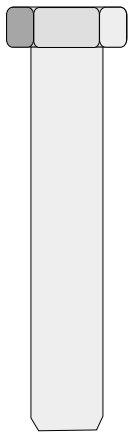
24

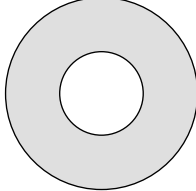
 3/8"-16
 HEX NUT
 (4 PIECES)

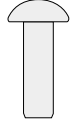
29

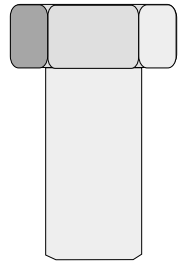
 3/8-16 X 2"
 Hex Bolt
 (4 Pieces)

26

 3/8"
 FLAT WASHER
 (8 PIECES)

32

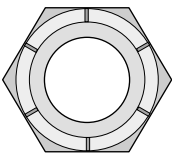
 #10 x 1/2"
 Thread Forming Screw
 (4 Pieces)

19

 1/2-13 x 1"
 Hex Bolt
 (2 pieces)

These parts are located inside rim kit

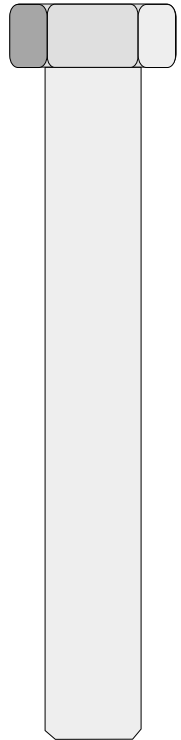
4

 1/2"
 Nylock Nut
 (7 pieces)

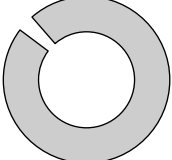
41

 Pull Pin
 (1 piece)

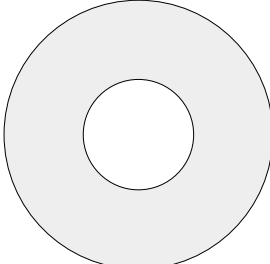
7

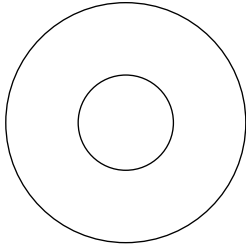
 1/2-13 x 10"
 Hex Bolt
 (3 pieces)

18

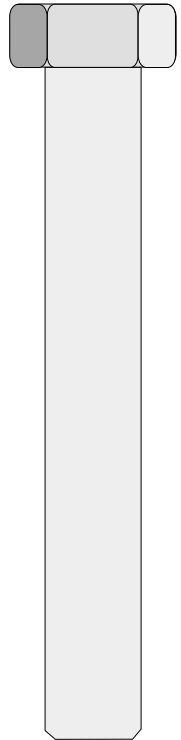
 1/2"
 SPLIT WASHER
 (2 PIECES)

3

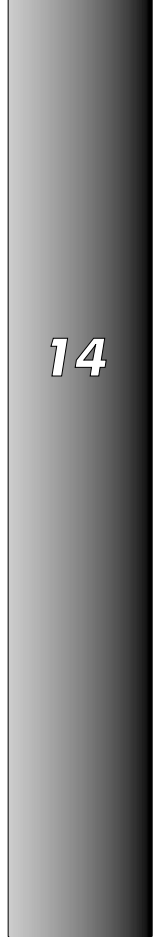
 1/2" Flat Washer
 (12 pieces)

5

 1-1/4" DIA. PLASTIC WASHER
 (20 PIECES)

20

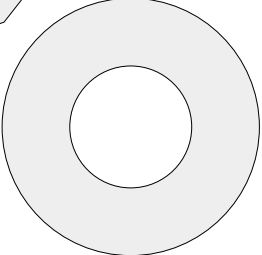
 1/2-13 x 4"
 Hex Bolt
 (4 pieces)

14

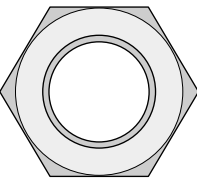
 Pivot Tube
 (1 piece)

34

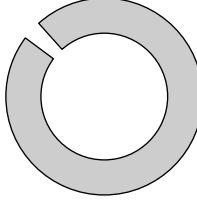
 5/8" THREAD
 PROTECTOR
 (4 PIECES)

37

 5/8" Flat Washer
 (8 pieces)

35

 5/8"
 Nylock Nut
 (12 pieces)

36

 5/8"
 SPLIT WASHER
 (4 PIECES)

WELCOME TO THE FAMILY OF GOALRILLA™ OWNERS

In order to have the safest fun and longest use of your Goalrilla™ system, please note and heed the following:

1. Prior to main post preparation and goal assembly, call utility services for location of underground utility lines before you dig.
2. Vertical main post assembly is a two part process.

PART 1

- Day 1. Complete Anchor System Installation Instructions. (Below)
- Day 2. Allow concrete to cure.
- Day 3. Allow concrete to cure.
- Day 4. Allow concrete to cure.

PART 2

- Day 5. Complete Goalrilla™ assembly instructions.

3. For safety measures have at least 3 capable persons to assist you in assembly of your Goalrilla™ Goal.

ANCHOR SYSTEM INSTALLATION INSTRUCTIONS (Day 1)

WARNING

Before digging the hole for this pole, check for buried power, gas, water, and telecommunication lines! Failure to do so could result in serious or fatal injury! Contact your local utility company if unsure.

1. Determine the location of the goal. Position the hole close to the playing surface without making contact. Dig a hole 16" in diameter and 48" below the playing surface. (See Figure 1)
2. Assemble anchor system as follows: Thread nut (#35) to bottom of threads on anchor bolt (#39) insert threads of anchor bolt (#39) through hole on anchor plate (#38) and secure with nut (#35). Repeat this step for the remaining anchor bolts. See Figure 2. Note: Each leg of anchor bolts should face the anchor bolt to the right. See Detail A.

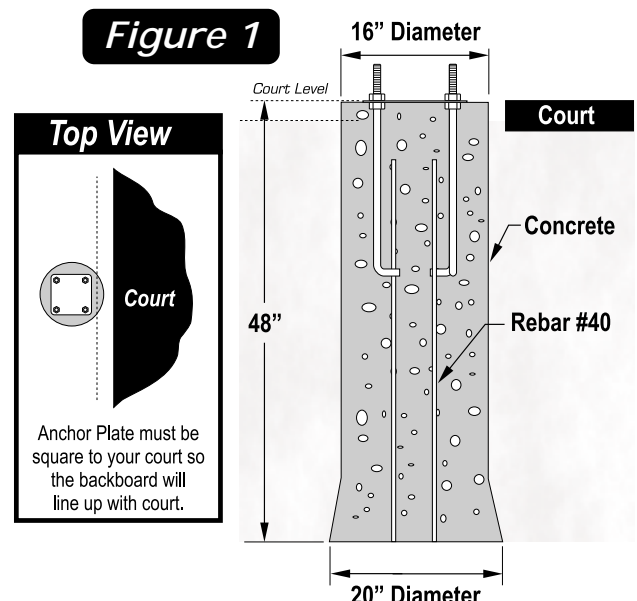
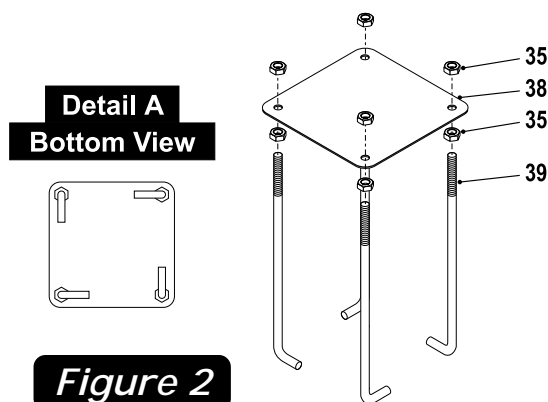

Note: It is recommended that you use some sort of concrete form for the top 4" of the concrete. Cardboard forms can be purchased at some hardware and home stores or a wooden form can be constructed out of 2 x 4's.

3. Mix and pour concrete into hole. Follow instructions on concrete bag. Stop about 18" below court level.
4. Insert four reinforcement bars (#40) into concrete 8" apart creating a square in center on hole.
5. Finish pouring concrete up to court level.
6. Push anchor system into concrete and agitate to work out voids in concrete. Immediately use a level to level and square anchor plate to playing surface. Clean off any concrete that may be on exposed threads. Note: The bottom four nuts will be forever embedded in concrete.

Let concrete stand for a MINIMUM of 72 hours.

GOALRILLA™ III ASSEMBLY INSTRUCTIONS (Day 5)

NOTE: It is important for the installer to understand the necessity of the nylon washers (#5) provided. These washers adequately space painted parts at all pivot points. Neglecting the use of these washers will result in rusted parts.

NOTE: All board arms are made of rectangular tubing. Tightening hardware too tight may damage tubing and make adjustment of system difficult.

1. Slide Actuator Sleeve (#15) over Actuator (#16) and place Actuator Cap (#13) on top. Slide Pivot Tube (#14) in hole near the top of Actuator until equal amounts stick out on both sides of Actuator. See Figure 3. **NOTE:** It may be necessary to use a hammer or rubber mallet to tap in Spacer.

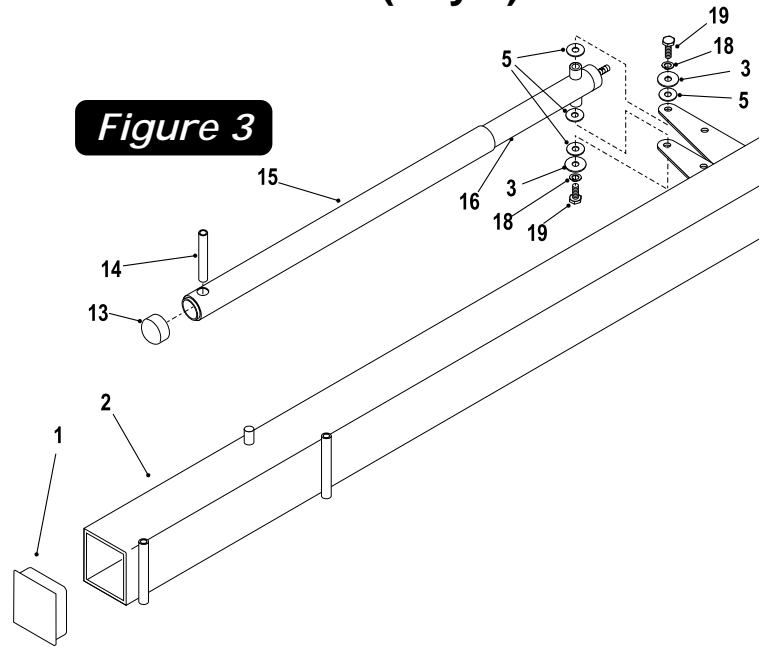

2. Lay Pole (#2) on its side on two padded saw horses. Secure Actuator (#16) to Pole (#2) using one bolt (#19), split lockwasher (#18), washer (#3) and two plastic washers (#5) to thread into each side of Actuator. See Figure 3. Tighten bolts tight.
3. Insert Pole Cap (#1) into top of Pole (#2). It may be necessary to use a hammer or rubber mallet to tap Cap in.

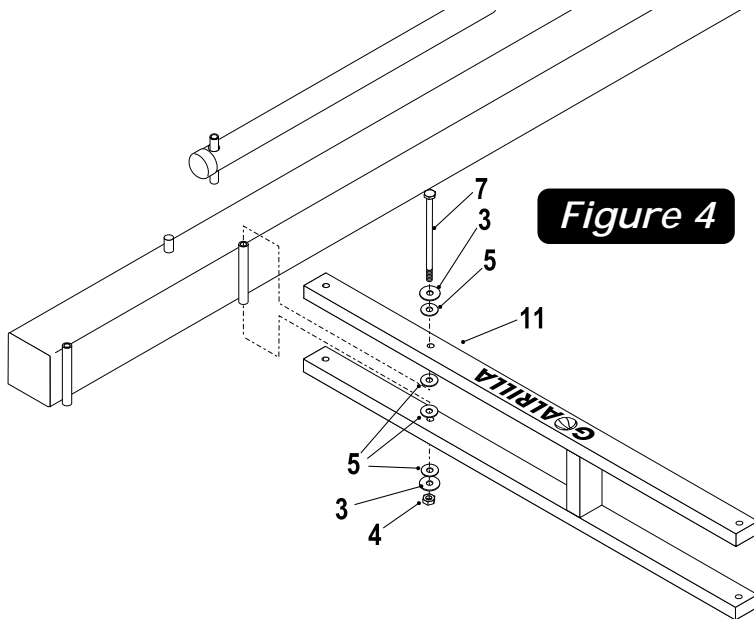

4. Attach lower arm (#11) to Pole (#2), as shown in Figure 4, using a bolt (#7), two flatwashers (#3), four plastic washers (#5) and hex nut (#4). **Note:** make sure "Goalrilla lettering is right side up. Do NOT tighten bolt (#7) at this time.
5. Secure Actuator (#16) to Lower Arm (#11) using one bolt (#7), two flatwashers (#3), four plastic washers (#5) and one hex nut (#4). See Figure 5. Tighten both bolts (#7) securing Lower Arm (#11). **Important!** Tighten bolts snug but, do not over tighten. Board Arms must pivot freely.
6. If the four Tube Plugs (#9) are not already installed insert them into open ends of Lower Arm (#11). It may be necessary to use a hammer or rubber mallet to tap them in.

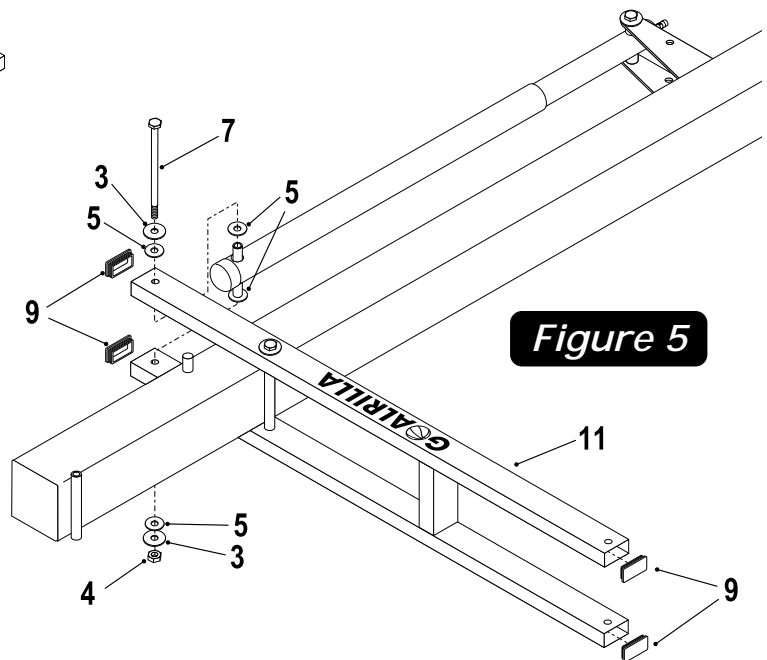

- Attach Upper Arms (#6) to Pole (#2), as shown in Figure 6, using a bolt (#7), two flatwashers (#3), four plastic washers (#5) and hex nut (#4). Tighten bolts snug but, do not over tighten. Board Arms must pivot freely.
- If the four Tube Plugs (#9) are not already installed insert them into open ends of Upper Arms (#6). It may be necessary to use a hammer or rubber mallet to tap plug in.

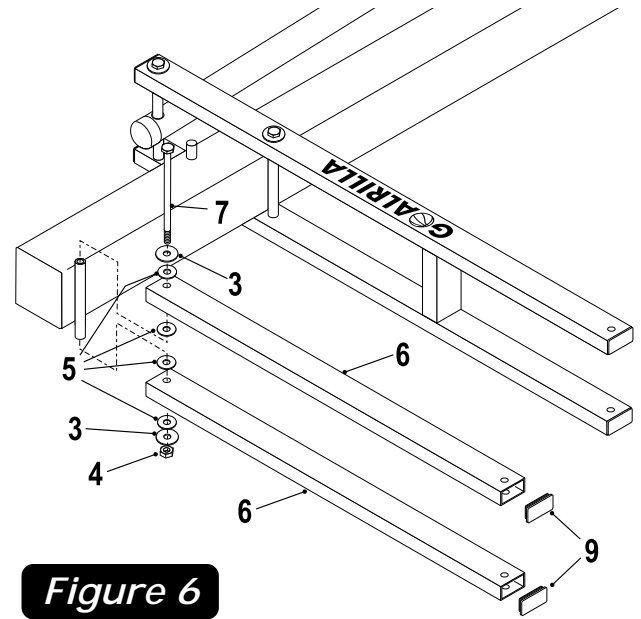

Figure 6

! CAUTION!

PLACING THE POST ON THE ANCHOR SYSTEM REQUIRES AT LEAST FOUR CAPABLE ADULTS. POLE WILL WANT TO LEAN WHILE ATTEMPTING TO STAND IT UP ON ANCHOR BOLTS.

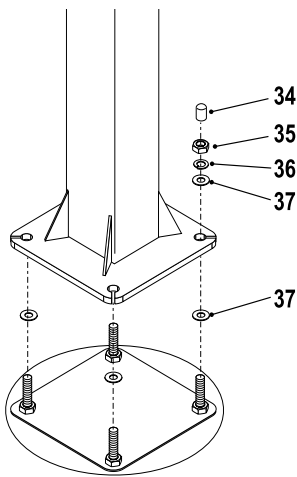

Figure 7

BE SURE CONCRETE HAS BEEN ALLOWED TO CURE FOR AT LEAST 3 DAYS

- Locate hardware needed to mount pole to anchor bolts. You will need, eight flatwashers (#37), four lock washers (#36), four hex nuts (#35) and four thread protectors (#34).
- Put a flat washer (#37) on each anchor bolt. Lift post onto anchor system and secure with one flatwasher (#37), one lock washer (#36) and one hex nut (#35) for each anchor bolt. Tighten all four hex nuts tight.

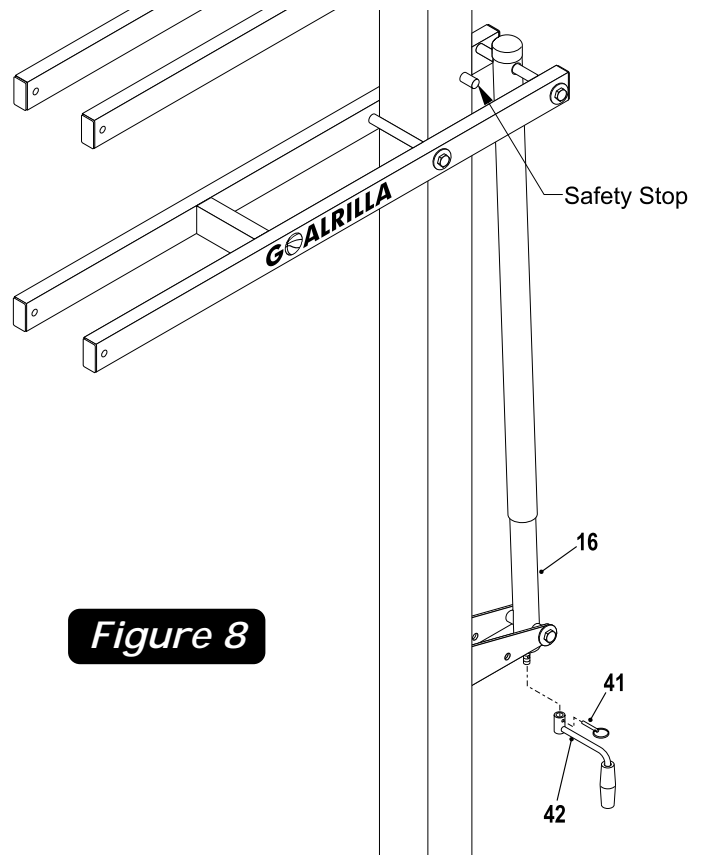

Figure 8

- Slide Actuator Crank (#42) onto shaft on the bottom of Actuator (#16). Line up hole in shaft with hole in Actuator Crank and insert Pin (#41) to secure.
- To aid in the assembly of the backboard lower the backboard, by turning the Actuator Crank, until the lower arm makes contact with the Safety Stop.

CAUTION!

ATTACHING BACKBOARD TO BOARD ARMS REQUIRES AT LEAST FOUR CAPABLE ADULTS.

- With at least three capable people, raise the backboard assembly up and have the fourth attach Lower Board Arms to lower mounting tubes on backboard using two bolts (#20), four Board Bushings (#22) (shipped already installed), two plastic washers (#5), two washers (#3) and two hex nuts (#4). See Figure 9. Do NOT over tighten these bolts. This is a pivot point. Snug is tight enough.
- Attach Upper Board Arms to upper mounting tubes on backboard using two bolts (#20), four Board Bushings (#22) (shipped already installed), two plastic washers (#5), two washers (#3) and two hex nuts (#4). See Figure 9. Do NOT over tighten these bolts. This is a pivot point. Snug is tight enough.

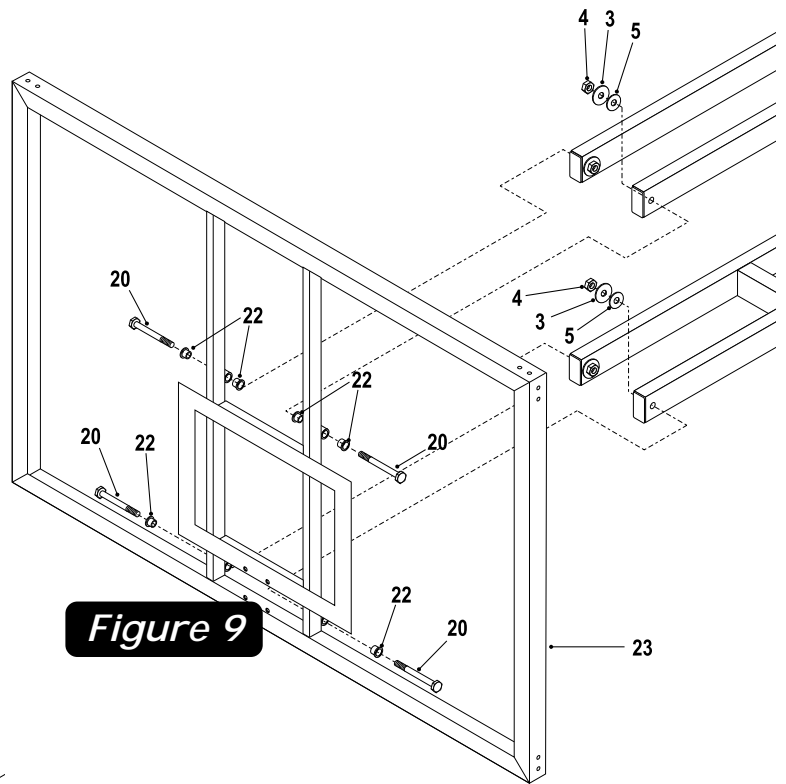
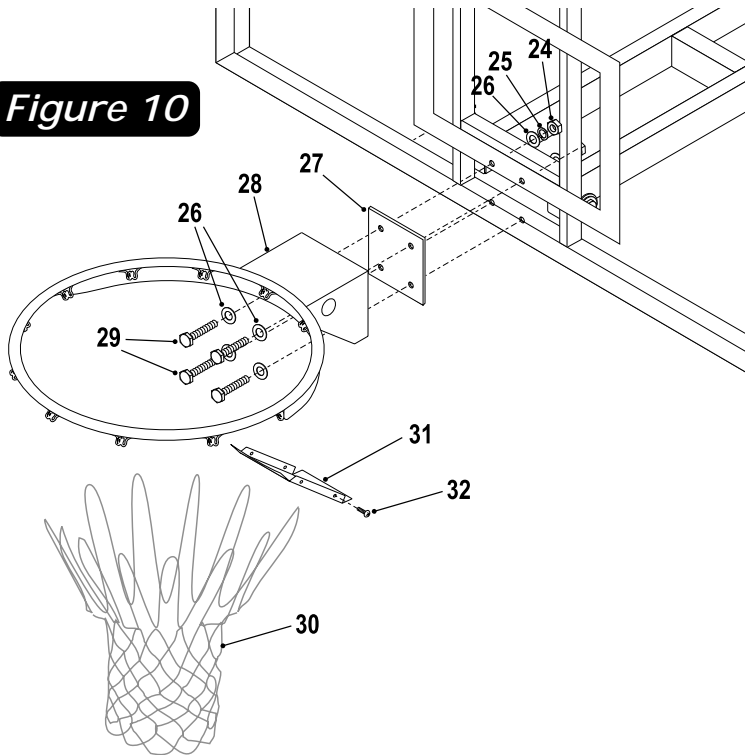

Figure 9

Figure 10



- Remove protective backboard covering and mount Goal Assembly (#28) and Rim Pad (#27) to Backboard, as shown in Figure 10, using four bolts (#29), eight washers (#26), four lockwashers (#25) and four nuts (#24). Tighten fasteners finger tight, leave them loose enough to level rim.
- Place a level across rim assembly and adjust rim until it is level. Finish tightening the four nuts.
- Attach Rim Cover Plate (#31) using four screws (#32). See Figure 10. CAUTION! Never use rim with coverplate removed!
- Check all nuts and bolts and make sure everything is tightened properly. Do NOT over tighten pivot points, snug is tight enough.

- Adjust unit to 7-1/2 feet. Use a tape measure to measure from the top of the rim to the playing surface. Stick Height Decal (#17) to back of Actuator (#16) with the "7.5" mark aligned with bottom of Actuator Sleeve (#15). See Figure 11.

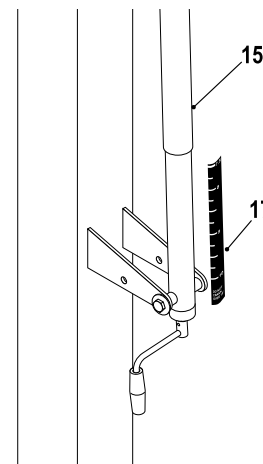

Figure 11

GOALRILLA™ CARE INFORMATION

- BACKBOARD -

Items needed to clean backboard:

- 100% cotton soft cloth, (only)
- Mild dish washing liquid for soap
- Luke warm water
- Mild plastic polish to minimize scratches

Rinse backboard with lukewarm water. Wash gently with a **100% Cotton** soft cloth, lukewarm water and **mild** soap. Do not scrub. Rinse backboard with lukewarm water again. Dry with **100% cotton** soft cloth. To minimize scratches and minor abrasions to your backboard, apply a **mild** polish such as Johnson's Paste Wax, Novus Plastic Polish #1 or Mirror Glaze Plastic Polish. Strong cleansers will damage backboard and void warranty.

- RIM -

HANGING ON THE RIM WILL VOID YOUR WARRANTY. Rims are not warranted for any defects other than workmanship. Torn back plates, damaged springs, bent rings, damaged eye bolts, and torn or distorted rim supports result from hanging on the rim and are not warranted.

The goal should not be cranked under 7' or over 10'. Adjustments of the goal should be done under adult supervision.

When attempting slam dunk activity you should always wear a mouth guard to avoid dental injury.

LIMITED LIFETIME WARRANTY

Subject to proper installation and normal use, Escalade Sports warrants, subject to the limitations below, to the original retail purchaser all structural components of the Goalrilla System to be free of defects in material and workmanship for the duration of ownership by the original retail purchaser.

Merchandise must be shipped prepaid with a copy of proof of purchase to our factory for examination to see whether it needs to be repaired or replaced. Any labor costs, travel expenses and any other charges involved in the removal, installation or replacement of the defective/repared parts from/to your Goalrilla System will be your (the purchaser's) responsibility. Shipping charges for replaced or warranted merchandise being sent back to the customer from our factory must be prepaid by the customer in advance. If not, the replacement shipment will be sent out collect.

Escalade Sports reserves the right to examine photographs or physical evidence of merchandise claimed to be defective, and to recover said merchandise, prior to authorization of warranty claims. A "Returned Goods Authorization" number may be required, please call for details prior to the return of any photographs or merchandise.

This warranty is expressly in lieu of all warranties, expressed or implied, including warranties of merchantability or fitness for use. Escalade Sports does not assume or authorize any person or representative to assume for us, any other liability in connection with the sale of our products.

The remedy of repair or replacement stated above is our exclusive remedy. Escalade Sports will not be liable for any other damages or expenses which may incur, including but not limited to incidental or consequential damages. Escalade Sports assumes no other obligations or liability on the part of the purchaser, and Escalade Sports neither assumes nor authorizes any other person to assume for it any other liability in connection with the goods sold.

What is Not Covered by This Warranty

- Any merchandise subjected to abuse, negligence, improper installation, vandalism, acts of God, alteration of product, or any other events beyond the control of Escalade Sports.
- Paint or rusted parts. Paint kits will be available to assist in normal maintenance.
- **HANGING ON RIM WILL VOID YOUR WARRANTY:** Rims are not warranted for any defects other than workmanship. Torn back plates, damaged springs, bent rings, damaged eyebolts, and torn or distorted rim supports result from hanging on the rim and are not warranted.
- Shipping charges both ways. Note: Any merchandise shipped to Escalade Sports collect will be refused.
- Dealer service charges, labor charges and travel expenses associated with replacement of repair of warranty item.

WARRANTY GUIDELINES

1. Keep your proof of purchase (original retail purchaser). Without it, we will not be able to proceed with any warranty service.
2. Call or write Escalade Sports Inc. to receive a Return Authorization # and allow us to better guide you with your specific needs.

1-888-USA-GOAL / Warranty Dept.

Or Write us at:

Escalade Sports Inc. - P.O. Box 889, Evansville, IN 47706 - Attn: Warranty Dept.

Or E-mail us at: customerservice@escaladesports.com

<i>Key#</i>	<i>Part #</i>	<i>Description</i>	<i>Qty.</i>
1	3M-6474-00	4" Square Tube Plug	1
2	1A-6295-01	Post Assembly	1
3	2B-6093-00	1/2 Flat Washer	12
4	2B-6095-00	1/2-13 Nylon Locknut	7
5	3M-6245-00	1-1/4" OD Plastic Washer	20
6	8S-6543-01	Upper Board Arm	2
7	1B-6222-00	1/2-13 X 10" Hex Bolt-Grade 5	3
9	3M-6465-00	1-1/2 X 2-1/2 Tube Plug	8
11	1A-6304-01	Lower Board Arm	1
12	4L-7283-00	Goalrilla Decal	2
13	3M-6467-00	Actuator Cap	1
14	8S-6565-01	Pivot Tube	1
15	2M-6160-00	Actuator Sleeve	1
16	4A-6551-00	Actuator	1
17	4L-7287-00	Height Decal	1
18	2B-6094-00	1/2 Split Lock Washer	2
19	1B-6215-00	1/2-13 X 1" Hex Bolt	2
20	1B-6216-00	1/2-13 X 4 Hex Bolt	4
22	7B-6243-00	Board Bushing	8
23	6A-6333-01	Backboard Assembly	1
24	901-118	3/8-16 Hex Nut	4
25	901-69	3/8 Split Lockwasher	4
26	701-50	3/8 STD Washer	8
27	3M-6473-00	3X4 Rim Pad	1
28	6A-6329-01	Goal Assembly	1
29	1B-6448-00	3/8-16 X 2" Hex Bolt	4
30	3F-6010-00	Net	1
31	2S-6427-00	Rim Cover Plate	1
32	1B-6238-00	#10 x 1/2 Thread Forming Scr.	4
33	3M-6470-00	Board Arm Stop Cover	2
34	3M-6469-00	5/8 Thread Protector	4
35	2B-6097-00	5/8-11 Hex Nut	12
36	2B-6099-00	5/8 Split Lockwasher	4
37	2B-6098-01	5/8 SAE FLAT WSHR ZNC	8
38	2S-6380-01	Anchor Plate	1
39	2B-6096-00	5/8-11 X 18 "J" Bolt	4
40	1S-6152-00	#3 X 40" Rebar	4
41	7B-6255-00	Pull Pin	1
42	4A-6550-00	Actuator Handle	1
43	2L-6631-00	This Manual	1

