

GROUND ANCHOR INSTALLATION INSTRUCTIONS

⚠ WARNING

- Failure to follow these instructions may result in death, serious injury and/or property damage and will void the warranty. Do not install or use this product unless the instructions within this manual have been carefully read and understood.
- Locate your goal away from potential dangers, including walls, trip hazards, high-traffic areas or where a vehicle might come into contact with goal post or backboard or rim.

To avoid severe injury or death, do not locate goal under power lines that may come into contact with the goal as it is raised.

⚠ WARNING

Before digging for the ground anchor, contact your local One-Call system (dial 811) in your area.



Utility Markings

Color	Definition
Red	Electric
Yellow	Gas, Oil, Petroleum
Orange	Communication, Phone, TV
Blue	Potable Water, Irrigation
Green/Brown	Sewer
White	Proposed Dig

- Installation and assembly of this product will require lifting and bending that may result in injury to anyone not accustomed to this type of activity.
- If an auger or post hole digger is used, be sure you read and follow all instructions, warnings and cautions for such equipment.
- Ensure there are no overhead power lines within a 20 ft. (7 m) radius of the goal location.

Determine Installation Location

Consider the following to determine where to install your Goalsetter® Basketball Goal:

- When extended, will backboard overhang obstruct driveway or other important space?
- Is there room so vehicles backing out of driveway do not strike backboard or rim?
- Will court markings be used?
- How much playing surface is needed?
- How much playing surface will be under the backboard? (Having the edge of the playing surface underneath the backboard can result in trip hazards and unpredictable ball action following a shot. Try to have as much playing surface as possible behind the backboard.)
- Will the goal be at least 20 ft. (7 m) from any overhead power lines? (No overhead power lines should be within a 20 ft. (7 m) radius of the goal.)

- Will the ground anchor for the goal avoid underground power, gas, telephone, water and other utility lines? (See 811 One Call Warning box for more information or call your local utility company.)
- Other functions of the playing surface (driveway, playground, etc.)

Required Tools and Materials:

- Spade
- Shovel
- Tape Measure
- Wheelbarrow
- Hoe
- Water
- Level
- Stir Rod
- Cement Trowel
- Auger/Post Hole Digger (optional)
- 10-14, 60 lb Bags of Dry Concrete Mix (or 1/4-1/3 yard of ready mix concrete)

Ground Anchor Installation

Step 1: Locate and unpack ground anchor. Remove plastic plugs from bolt holes and ensure the threads are in good condition. **REPLACE THE PLUGS** – they will keep debris from the bolt holes during installation. Leave the hinge pin in place as well.

Step 2: Determine hole location. When installed, the edge of the ground anchor plate must be a minimum of 6" (15.2 cm) away from the playing surface. Follow One Call or your utility's recommendations as to how close you may dig to a utility.

IMPORTANT

You **MUST** dig the anchor hole at least 48" (1.2 m) deep.

⚠ WARNING

Before digging for the ground anchor, check for underground power, gas, telephone, water and other utility lines. Failure to do so could result in serious injury. See 811 One Call Warning box for more information or call your local utility company.

Step 3: Dig hole 48" to 50" (1.2 m - 1.3 m) deep and 18" (0.5 m) in diameter using a spade, shovel, auger or post hole digger.

Refer to chart on back page for your goal's pole size.

4" pole = 14-16" diameter hole
5" pole = 16-18" diameter hole
6" pole = 18" diameter hole

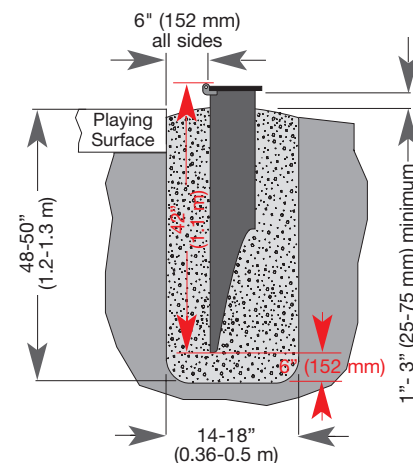

⌚ TIME OUT TIP: If you plan on mixing concrete in stages, work quickly to minimize time between batches.

Step 4: Mix concrete. Put concrete in wheelbarrow. Add the amount of water recommended on the bag, and mix with hoe.

Step 5: Begin adding concrete into hole until concrete is approximately 28"-30" (.7 - .8 m) deep.

⌚ TIME OUT TIP: The arrow on the decal **MUST** be pointing toward the playing surface.

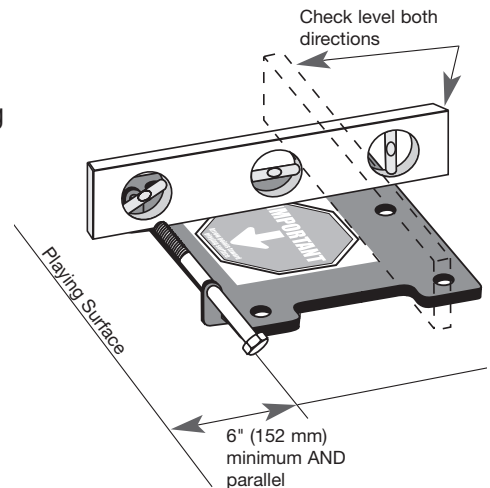

Step 6: Position anchor in center of hole with hinge side toward and parallel with playing surface. Using a level, ensure the anchor is level front-to-back and left-to-right. All edges of the ground anchor must be 6" (15.2 cm) away from all sides of hole and the top of the ground anchor within a range of 1"-3" (25-75 mm) above the level of the playing surface.

⌚ TIME OUT TIP: As you add concrete, occasionally insert a stir rod (such as a broomstick) into three or four places in the concrete and plunge up and down to help eliminate air bubbles.

Step 7: Continue adding concrete until concrete is within 1"-1.5" (25-38 mm) of anchor plate bottom, or level with the landscape - whichever comes first. Slope top of concrete away from pole with trowel to create a smooth surface.

IMPORTANT

- Periodically re-check the level of the anchor plate in both directions as you add more concrete.
- Slope the top of the concrete fill away from the ground anchor in all directions to shed moisture away.

⌚ TIME OUT TIP: If you must adjust the height, be sure to re-check level and that the anchor is parallel with the playing surface!

Step 8: If needed, adjust anchor plate height. The top of the ground anchor should be within a range of 1"-3" (25-75 mm) above playing surface. Be sure to re-check level.



Contact Us
 Phone 800.362.4625
 Fax 641.594.3343
 Email info@goalsettersystems.com
www.goalsettersystems.com

GOAL SPECIFICATIONS

Signature Series – Internal Jack

Model	Pole Size	Backboard Size	Weight w/Acrylic	Weight w/Glass	Height Range (A)	Extension Distance (B) at:			Maximum Overhang (C)	Distance Rim to Backboard (D)	Rim to Top-Of-Goal Distance (E)	Crank Distance (F)	Crank Height (G)	Offset Height (H)	Pole Height (I)	Offset Distance (J)
						10'	8'	6'								
MVP	6" x 6"	42" x 72"	525 lbs	585 lbs	6' - 10'	51"	54"	48"	79"	25"	33-3/4"	11-1/2"	36-1/2"	7'-0"	10'-5"	21"
Captain	6" x 6"	38" x 60"	510 lbs	560 lbs	6' - 10'	51"	54"	48"	79"	25"	29-3/4"	11-1/2"	36-1/2"	7'-0"	10'-5"	21"
All American	5" x 5"	38" x 60"	385 lbs	435 lbs	6' - 10'	38"	42"	37"	67"	25"	29-3/4"	10-1/2"	36-1/2"	6'-6"	9'-8"	16"
All Star	5" x 5"	36" x 54"	370 lbs	410 lbs	6' - 10'	38"	42"	37"	67"	25"	27-3/4"	10-1/2"	36-1/2"	6'-6"	9'-8"	16"
Contender	4" x 4"	36" x 54"	310 lbs	345 lbs	6' - 10'	32"	36"	28"	61"	25"	27-3/4"	10-1/2"	36-1/2"	6'-6"	9'-8"	13-1/2"
Champion	4" x 4"	32" x 48"	300 lbs	335 lbs	6' - 10'	32"	36"	28"	61"	25"	23-3/4"	10-1/2"	36-1/2"	6'-6"	9'-8"	13-1/2"

Signature Series – External Jack

Model	Pole Size	Backboard Size	Weight w/Acrylic	Weight w/Glass	Height Range (A)	Extension Distance (B) at:			Maximum Overhang (C)	Distance Rim to Backboard (D)	Rim to Top-Of-Goal Distance (E)	Crank Distance (F)	Crank Height (G)	Offset Height (H)	Pole Height (I)	Offset Distance (J)
						10'	8'	6'								
MVP	6" x 6"	42" x 72"	525 lbs	585 lbs	6' - 10'	51"	54"	48"	79"	25"	33-3/4"	23"	69"	7'-0"	10'-5"	21"
Captain	6" x 6"	38" x 60"	510 lbs	560 lbs	6' - 10'	51"	54"	48"	79"	25"	29-3/4"	23"	69"	7'-0"	10'-5"	21"
All American	5" x 5"	38" x 60"	375 lbs	425 lbs	6' - 10'	38"	42"	37"	67"	25"	29-3/4"	27"	62"	6'-6"	9'-8"	16"
All Star	5" x 5"	36" x 54"	360 lbs	400 lbs	6' - 10'	38"	42"	37"	67"	25"	27-3/4"	27"	62"	6'-6"	9'-8"	16"
Contender	4" x 4"	36" x 54"	300 lbs	335 lbs	6' - 10'	32"	36"	28"	61"	25"	27-3/4"	22"	64"	6'-6"	9'-8"	13-1/2"
Champion	4" x 4"	32" x 48"	290 lbs	325 lbs	6' - 10'	32"	36"	28"	61"	25"	23-3/4"	22"	64"	6'-6"	9'-8"	13-1/2"

Signature Series – Fixed Height

Model	Pole Size	Backboard Size	Weight w/Acrylic	Weight w/Glass	Height Range (A)	Extension Distance (B) at:			Maximum Overhang (C)	Distance Rim to Backboard (D)	Rim to Top-Of-Goal Distance (E)	Crank Distance (F)	Crank Height (G)	Offset Height (H)	Pole Height (I)	Offset Distance (J)
						10'	8'	6'								
MVP	6" x 6"	42" x 72"	525 lbs	585 lbs	10'	51"	-	-	76"	25"	33-3/4"	-	-	7'-0"	10'-5"	21"
Captain	6" x 6"	38" x 60"	510 lbs	560 lbs	10'	51"	-	-	76"	25"	29-3/4"	-	-	7'-0"	10'-5"	21"
All American	5" x 5"	38" x 60"	375 lbs	425 lbs	10'	38"	-	-	63"	25"	29-3/4"	-	-	6'-6"	9'-8"	16"
All Star	5" x 5"	36" x 54"	360 lbs	400 lbs	10'	38"	-	-	63"	25"	27-3/4"	-	-	6'-6"	9'-8"	16"
Contender	4" x 4"	36" x 54"	300 lbs	335 lbs	10'	32"	-	-	57"	25"	27-3/4"	-	-	6'-6"	9'-8"	13-1/2"
Champion	4" x 4"	32" x 48"	290 lbs	325 lbs	10'	32"	-	-	57"	25"	23-3/4"	-	-	6'-6"	9'-8"	13-1/2"

Tournament Series

Model	Pole Size	Backboard Size	Weight w/Acrylic	Weight w/Glass	Height Range (A)	Extension Distance (B) at:			Maximum Overhang (C)	Distance Rim to Backboard (D)	Rim to Top-Of-Goal Distance (E)	Crank Distance (F)	Crank Height (G)	Offset Height (H)	Pole Height (I)	Offset Distance (J)
						10'	8'	6'								
Elite	4" x 4"	32" x 48"	250 lbs	280 lbs	7'-10'	26-1/2"	34"	29-1/2"	59"	25"	23-3/4"	-	-	-	9'-8"	-

Extreme Series

Model	Pole Size	Backboard Size	Weight w/Acrylic	Weight w/Glass	Height Range (A)	Extension Distance (B) at:			Maximum Overhang (C)	Distance Rim to Backboard (D)	Rim to Top-Of-Goal Distance (E)	Crank Distance (F)	Crank Height (G)	Offset Height (H)	Pole Height (I)	Offset Distance (J)
						10'	8'	6'								
X672	6" x 6"	42" x 72"	475 lbs	535 lbs	6'8"-10'	42"	48"	46"	73"	25"	33-3/4"	18"	42"	-	10'	-
X660	6" x 6"	38" x 60"	460 lbs	515 lbs	6'8"-10'	42"	48"	46"	73"	25"	29-3/4"	18"	42"	-	10'	-
X560	5" x 5"	38" x 60"	375 lbs	430 lbs	6'8"-10'	36"	43"	40"	68"	25"	29-3/4"	18"	42"	-	9'-9"	-
X554	5" x 5"	36" x 54"	360 lbs	400 lbs	6'8"-10'	36"	43"	40"	68"	25"	27-3/4"	18"	42"	-	9'-9"	-
X454	4" x 4"	36" x 54"	260 lbs	300 lbs	6'8"-10'	31"	36"	31"	61"	25"	27-3/4"	18"	42"	-	9'-9"	-
X448	4" x 4"	32" x 48"	255 lbs	285 lbs	6'8"-10'	31"	36"	31"	61"	25"	23-3/4"	18"	42"	-	9'-9"	-

GOAL SPECIFICATIONS ILLUSTRATION

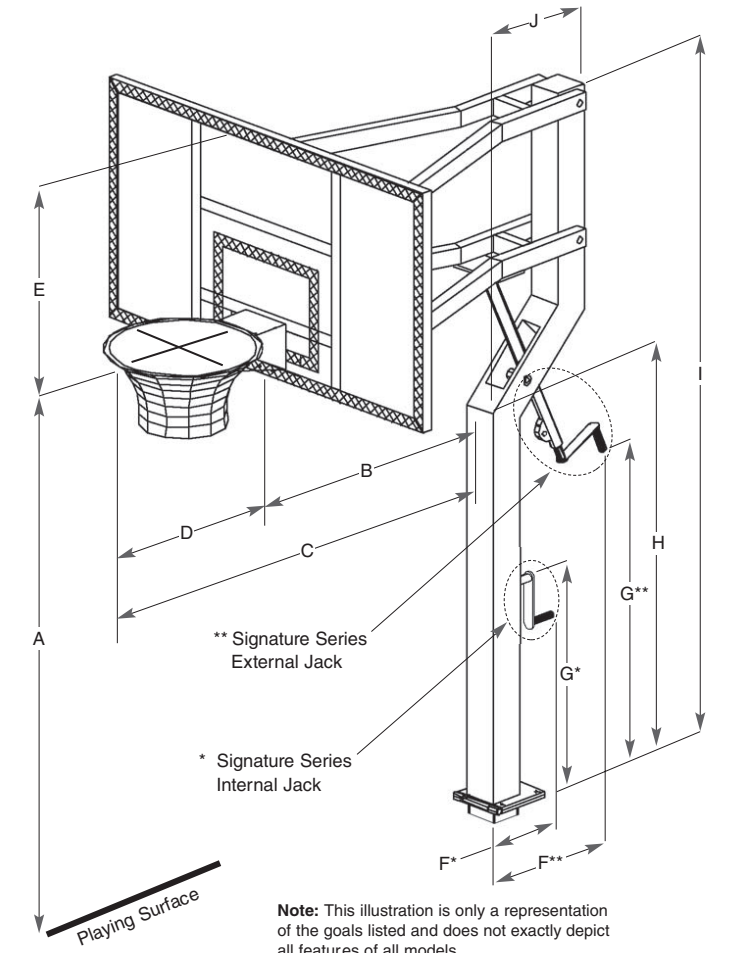

COURT MARKINGS (Reference Only)

Regulation Court Lengths
High School: 84'
College and Professional: 94'

